

Part number

CHIW 10

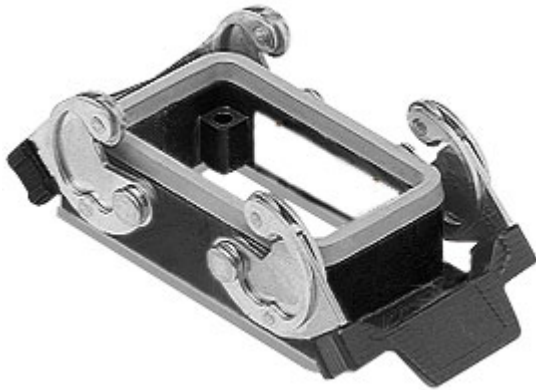

Brief description:

bulkhead mounting housings with 2 levers, size "57.27", aggressive environments, IP66

Product description

Version	W-TYPE version for aggressive environments
Series	bulkhead mounting housings with 2 levers
Product type	with 2 levers
Family	CLASS enclosures
Size	size "57.27"

Technical data

Material	metal
IP degree of protection	IP66 (and IP69K DIN 40050 - 9)

Further technical details

Weight	170,00 g
---------------	----------

Approvals / Standards

Quality mark	 (type:4/4X/12),  , EAC
Conformity	CQC, CE

General ordering information

EAN13 code	8015747019361
Tariff number	85369095

Packaging Information

Sub-packaging weight	0,85 kg
Sub-packaging description	Plastic packaging
Sub-packaging quantity	5 Pcs
Sub-packaging EAN barcode	8015747102247

Part number

CHIW 10



Catalogue drawings

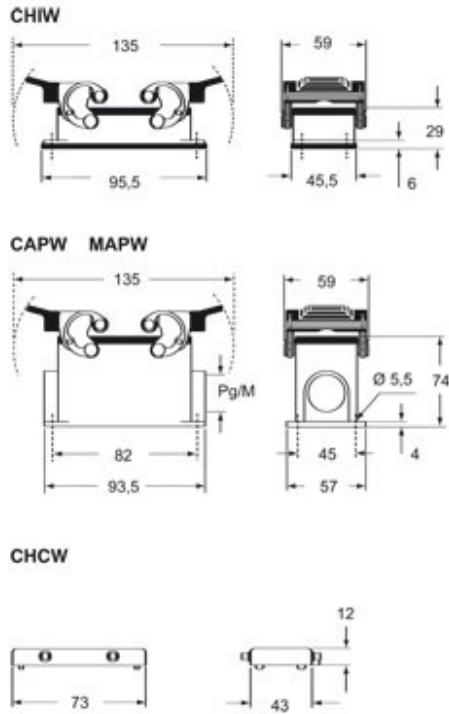

Catalogue drawings

